

THE ULTIMATE

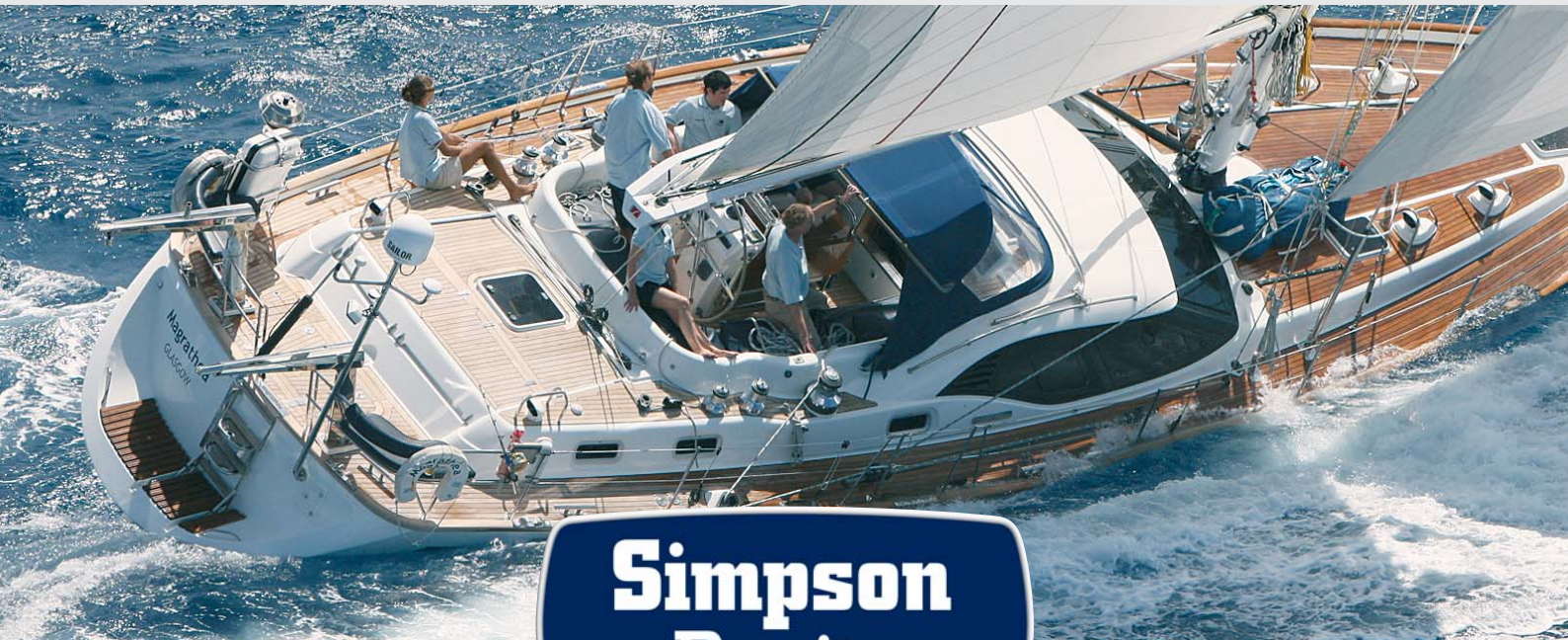

Simpson Davits

SIMPSON DAVITS S10 DAVIT WITH DYNEEMA LIFTING ROPE



The S10 Davit new to the Simpson Davit range, offers strength and maximum style in an all-stainless Davit. Dyneema Lifting Rope is a strong, supple rope - 5 times stronger than steel on a weight-for-weight basis.



ADVANCED STAINLESS
• ENGINEERING •

SPECIFICATIONS

SERIES 10 DAVITS WITH DYNEEMA LIFTING ROPE

Simpson Davits

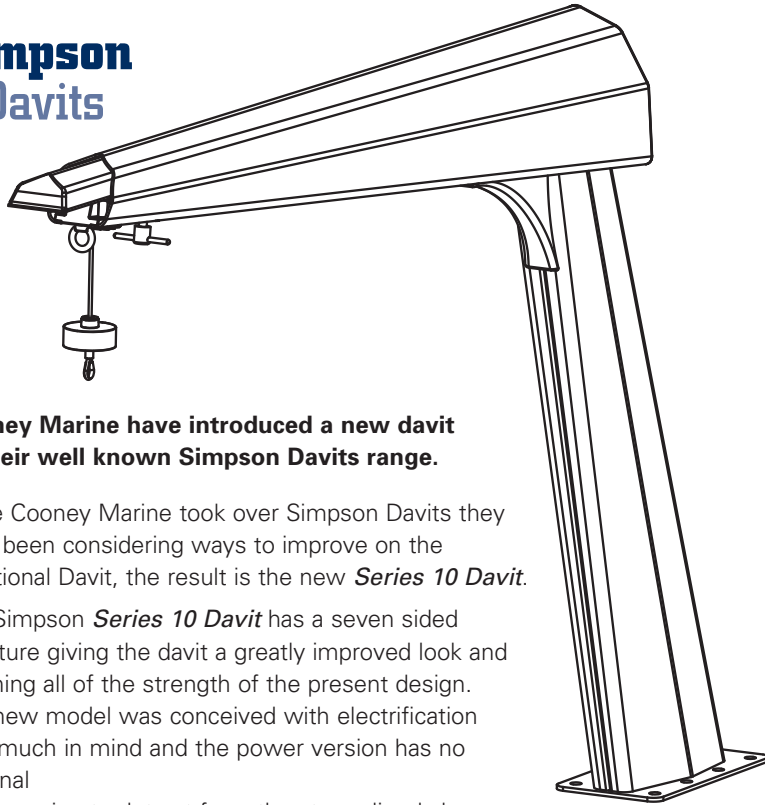

Cooney Marine have introduced a new davit to their well known Simpson Davits range.

Since Cooney Marine took over Simpson Davits they have been considering ways to improve on the Traditional Davit, the result is the new *Series 10 Davit*.

The Simpson *Series 10 Davit* has a seven sided structure giving the davit a greatly improved look and retaining all of the strength of the present design. The new model was conceived with electrification very much in mind and the power version has no external motor casing to detract from the streamlined shape.

Power winches have historically been avoided on sailing yachts due to the battery capacity on board, but this unit is designed to keep current drain to a minimum and make the powered option a first choice especially as manual override is fitted as standard.

The *Series 10 Davit* comes in standard, long reach and tall configurations (tall only available on S225/250 models) with lifting capacities from 150kg to 300kg per pair of davits (manual and electrical versions available).

White painted version also available.

Dyneema Lifting Rope



- New design gearbox and internal drum to allow safe and reliable lifting using Dyneema rope
- Can be retro fitted to existing davits simply by replacing the gearbox
- 5 times stronger than steel
- Little loss of strength during repeated bending, flexing and stretching
- Smoother running and reduced abrasion
- Reduced chance of injury from steel 'barbs'

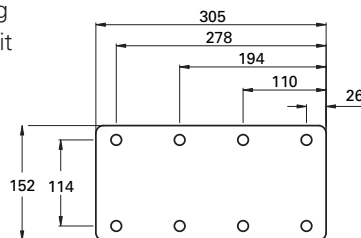

Baseplate S225, S225 Tall, S250, S250 Tall, S300

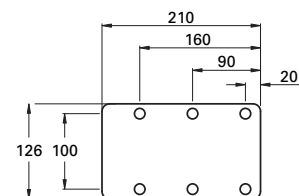

Baseplate S150, S175

MODEL	SWL per pair	A	B	C	D	E	F	G
S150	150kg	712	210	880	1015	535	650	68
S175	175kg	727	210	1245	1380	535	660	68
S225	225kg	866	305	1200	1410	665	795	68
S225 Tall	225kg	1045	305	1200	1455	850	970	68
S250	250kg	857	305	1045	1260	665	785	68
S250 Tall	250kg	1045	305	1045	1305	850	945	68
S300	300kg	1045	305	1200	1455	850	970	68

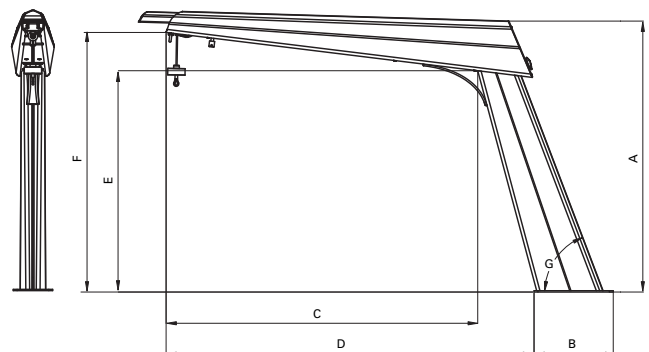

Cooney Marine International Limited Telford Way Kettering Northants NN16 8UN United Kingdom

Tel: +44 (0) 1536 484481 Fax: +44 (0) 1536 411580 e.mail: sales@cooneymarine.co.uk

www.cooneymarine.co.uk www.simpsondavits.co.uk